



SUBMITTAL DATA SHEET

Wall Mounted Heat Pump System	
Location: _____	Approval: _____
Engineer: _____	Date: _____
Submitted to: _____	Construction: _____
Submitted by: _____	Unit #: _____
Reference: _____	Drawing #: _____

Set Code	22022010018517
Indoor unit code	22022011017701
Outdoor unit code	22022016017440
Set Model	
Indoor unit model	EZ-24W-HP230
Outdoor unit model	EZ-24Z-HP230
Certified	
AHRI	
UL	



SYSTEM PERFORMANCE DATA

Power supply		
Normal Operational Voltage	(V, Ph, Hz)	208/230V, 1Ph, 60Hz
Voltage Range	(V)	187-253
Electrical		
Minimum circuit ampacity (Outdoor)	(A)	21
Max. fuse (Outdoor)	(A)	35
Connection wiring		14#x4//
Cooling		
Capacity	(Btu/h)	24000(6400-24900)
Power Input	(W)	2665(335-3050)
Current	(A)	11.8(2.1-13.4)
SEER2	(Btu/W)	18
EER2	(Btu/W)	9
Heating		
Capacity	(Btu/h)	25000(6700-27500)
Power Input	(W)	2380(485-3020)
Current	(A)	10.5(3.3-13.2)
HSPF2-4	(Btu/W)	8.3
HSPF2-5	(Btu/W)	6.5
COP	W/W	3.08
Heat at 17F(H32)	(Btu/h)	17200
Heat at 5F(H42)	(Btu/h)	15400
COP at 5F(H42)	W/W	1.83

REFRIGERANT PIPE DATA

Throttle type	Indoor unit	N/A
	Outdoor unit	Throttle Valve
Design pressure	(PSIG)	550/340
Refrigerant Type		R410A
Refrigerant charge	oz	65.96
	(ft)	25.0
Refrigerant precharge	(m)	7.5
Additional charge for each ft	(oz/ft)	0.32
Additional charge for each m	(g/m)	30
Liquid side/ Gas side(indoor)	(inch)	3/8"/5/8"
	(mm)	9.52/15.9
Liquid side/ Gas side(outdoor)	(inch)	3/8"/5/8"
	(mm)	9.52/15.9
Max. pipe length	(ft)	164.04
	(m)	50
Max. difference in level	(ft)	82.02
	(m)	25
Connection method		Flared
Indoor(cooling)	(Deg. °F)	60~90
	(Deg. °C)	16~32
Indoor(heating)	(Deg. °F)	32~86
	(Deg. °C)	0~30
Outdoor(cooling)	(Deg. °F)	5~122
	(Deg. °C)	-15~50
Outdoor(heating)	(Deg. °F)	5~75
	(Deg. °C)	-15~24

INDOOR UNIT DATA

Indoor fan motor		
Model		ZKFP-58-8-1-5
Qty		1
Input	(W)	58
Output	(W)	58.0
RLA	(A)	0.34
Speed(Hi/Mi/Lo)	(r/min)	1100/940/860
Air flow & Noise level		
Indoor air flow (Hi/Med/Lo) (No duct)	(CFM)	682.35/549.41/404.12/333.53
Indoor noise level (Hi/Med/Lo)	[dB(A)]	45/40.0/27
Dehumidification		
	(L/H)	2.97
Indoor unit		
Dimension (WxDxH)	(inch)	42.60x9.21x13.27
	(mm)	1082x234x337
Packing(WxDxH)	(inch)	46.73x17.68x14.29
	(mm)	1187x449x363
Net/Gross weight	(lbs.)	35.27/61.07
	(kg)	16/27.7

OUTDOOR UNIT DATA

Compressor		
Type		Twin-ROTARY
Model		KTM240D57UMT
Brand		GMCC
Capacity	(W)	7740
Input	(W)	2085
Rated current (RLA)	(A)	14.94
Refrigerant oil/oil charge	(ml)	ESTER OIL VG74 670
Outdoor fan motor		
Model		ZKFN-80-8-3
Qty		1
Input	(W)	/
Output	(W)	80
RLA	(A)	0.39
Speed	(r/min)	810/720
Air flow & Noise level		
Outdoor air flow (Max.)	(CFM)	1764.71
Outdoor noise level	[dB(A)]	60
Outdoor unit		
Dimension (WxDxH)	(inch)	35.04x13.46x26.50
	(mm)	890x342x673
Packing (WxDxH)	(inch)	39.17x15.67x29.13
	(mm)	995x398x740
Net/ Gross weight	(lbs.)	97.66/104.28
	(kg)	44.3/47.3

Indoor unit dimension

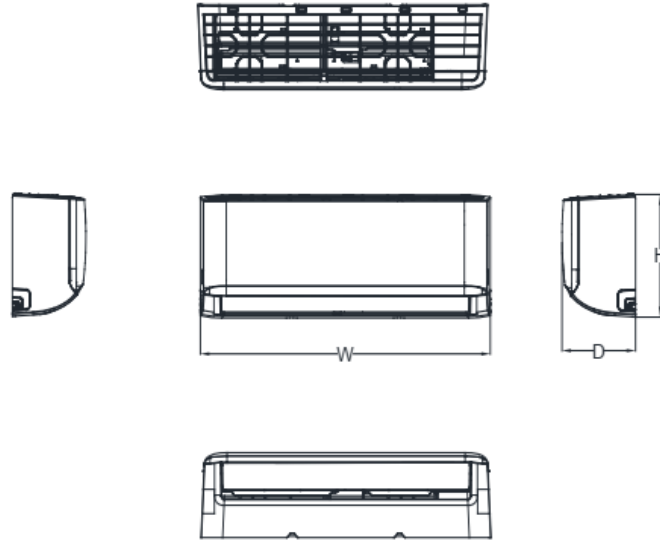

Capacity	Body Code	W(mm/inch)	D(mm/inch)	H(mm/inch)
6K~11K	A	729/28.7	200/7.87	292/11.5
8K~14K	B	802/31.57	200/7.87	295/11.61
12K~21K	C	971/38.23	228/8.98	321/12.64
18K~28K	D	1082/42.6	234/9.21	337/13.27
27K~36K	F	1259/49.57	283/11.14	362/14.25

Outdoor unit dimension

